

ACCESSORIES



Printer
Code: 1.402

External printer PR10 with 24 columns that provides both certification of parameters measured with an indication of tolerance and graphs of the profile.



Extension
Code: 1.406

Probe extension of 100 mm for measuring inside deep holes



External push-button
Code: 1.405

Button for the remote measure.



Stativo ST1
Code: 1.400

Granite stand ST1 is composed of 400 mm x 250 mm granite and a positioning column. Maximum height reached from the granite is 150 mm



Software MS lite
Code: 1.403

Measurement Studio Lite software allows you to download measurements and profiles, archive and statisticalise them as well as pre-configure the reports to print them.



PROBES

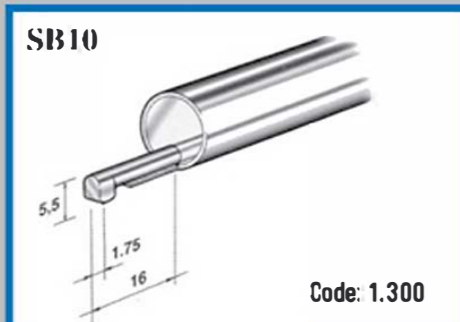

SB10

Code: 1.300

SB10 - Standard probe for plane surfaces or diameters internal/external larger than of 10 mm.



SB20

Code: 1.301

SB20 - For plane surfaces, grooves and shoulders with depth up to 5 mm.



SB30

Code: 1.302

SB30 - For planes and holes with diameters more than 4mm and deep up to 20mm.

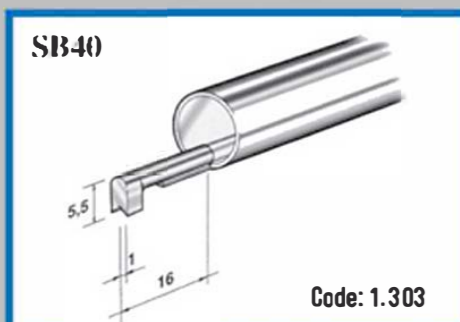

SB40

Code: 1.303

SB40 - "V" skid, for wires, and cylinders with external diameter more than 1 mm.

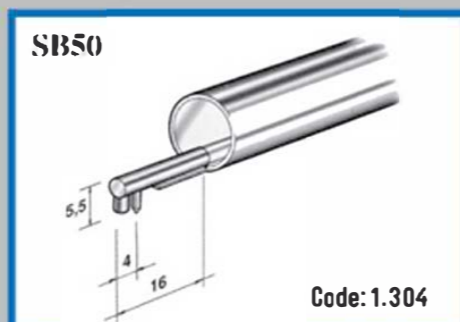

SB50

Code: 1.304

SB50 - With anterior skid, for plane or curve surfaces, ideal for measuring at 90°.

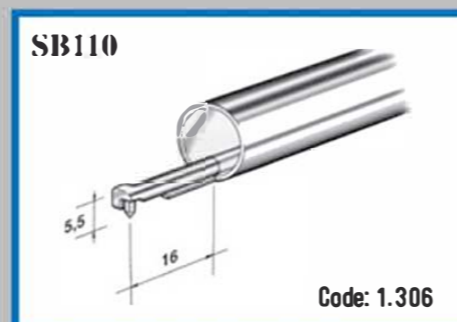

SB110

Code: 1.306

SB110 - For concave and convex surfaces with minimum radius of 5 mm.

TECHNICAL DATA

Roughness parameters	RT10	RT10G
	11 parameters: ISO 4287 - Ra, Rq, Rt, Rz, Rc, RSm, Rmr ISO 12085 - Pt, R, AR, Rx	31 parameters: ISO 4287 - Ra, Rq, Rt, Rz, Rp, Rc, Rv, Rsm, Rdc, Pa, Pq, Pt, Pp, Pc, Pv, Psm, RPc, PPc ISO 13565 - Rk, Rpk, Pvk, Mr1, Mr2 - ISO 12085 (CNDMD) - Pt, R, Rx, AR Altri- R3, R3zm, Rmax
Unit system	Millimetres and inches	Millimetres and inches
Cut-off length	0,25 - 0,8 - 2,5 mm	0,25 - 0,8 - 2,5 mm
Evaluation length	Fino to 16 mm	Fino to 16 mm
Measure range	±20 µm and ±80 µm	±200 µm
Resolution	0,01 µm and 0,04 µm	0,001 µm
Numerical filter	Gaussian accordant with ISO 11562	Gaussian accordant with ISO 11562
Interface	LCD display with 16 characters on 2 rows and waterproof membrane keyboard with 4 keys	2" TFT colour display and waterproof membrane keyboard with 4 keys
Languages	Italian, English, French, German, Spanish and Portuguese	Italian, English, French, German
Memory	Up to 1000 measurements	Up to 1000 measurements
Probe	The inductive probe is able to rotate to 90° for lateral measures	The inductive probe is able to rotate to 90° for lateral measures

Roughness tester RT10 - RT10G

The best way to measure



DIFFICULT MEASURES

Can the control of one particular be more difficult than its construction? We think no!

The roughness tester **RT10** and **RT10G** are the results of this philosophy: high manageability and ease of use.

To make a measurement and display graphs or parameters you just have to press a button. Measure the roughness? As simple as a click!

Top 10 reasons to choose RT10 and RT10G

Ease of use

Shortcut keys for quick access to common functions



Reliability

Always accurate measures due to nanometric sensors



Readability

LCD display for easy reading of results

Connectivity

USB interface to PC, printer and remote start button

Rapidity

Self-centering of the probe for quick measuring

Controllability

Measurements with only one hand thanks to considerably reduced size and weight

Flexibility

Rotation of the probe to 90° to enter laterally into the grooves



Interchangeability

Interchangeable probes thanks to the connector plug-in



Robustness

Alloy anodized base and removable nose protection



Simplicity of measure

Support with a "V" shape for the direct measurement on curved surfaces



With a simple act, the probe can rotate to 90° in both directions allowing you to measure transversally even most complex pieces.



The removable nose lets you measure with only one hand assuring a stable support also on more difficult geometries.



The instrument is equipped with two removable supports that make positioning easier on the part.

THE EQUIPMENT INCLUDES



Roughness tester RT10 or RT10G combined with probe SB 10

Battery charger unit 110-220V

Positioning supports

Shaft with 8 mm diameter for mounting on the stand

Roughness standard Ra 2,97 µm

Printer PR10 (optional)

Software Measurement Studio Lite with USB cable (optional)

Code: 1.100 RT10

The roughness tester **RT10** is the easiest instrument of the range. This device is ideal for measuring the part directly in the workshop or near production machines. The ease of use makes it suitable for all those needs where the roughness of the piece has to be characterized only numerically: in these conditions the analysis is very quick. Due to its internal memory, manoeuvrability and integrated battery, the **RT10** is perfect for measuring in difficult environments, for example if you have to analyse large or complex details.

The **RT10 Plus** (code: 1.101) has the connector plug-in that allows interchangeability of the probe, ensuring the possibility of measuring on all surfaces simply by replacing the stylus with the right one.

Code: 1.102 RT10G

The roughness tester **RT10G** comes from the experience gained on RT10; it inherits the reliability and ease handling and it is enhanced by advanced analysis typical of instruments you can find only in metrological laboratories. In addition to the 31 calculated roughness parameters, the **RT10G** displays graphs of the roughness and primary profile, curves of portance, ordinate distribution and allows you to set the tolerances on individual parameters and personalize reports. The **RT10G** uses the new electronics components with a resolution of 0.001 µm which provide more reliable results and present them in an easy and intuitive manner, thanks to the internal menu based on icons and derived from modern Smartphone.